

PRIOBOX

Feuerbeständige Fassbox

Feuerbeständiger Fass-Schrank zur Lagerung brennbarer Flüssigkeiten in Fässern bis zu 200 Liter. Geeignet als **Entnahmestelle für Gefahrstoffe am Arbeitsplatz**. Die Vorteile: chemisch hochbeständige Oberflächen innen und außen, unterfahrbar und günstiger Preis. Der Fass-Schrank bietet 90 Min. Feuerwiderstand.

Funktion

- Erfüllt die Anforderungen gemäß TRGS 510, WHG, GefStoffV, VAWS
- Feuerwiderstand 90 Minuten: feuerbeständig
- EI 90/F 90 Klassifizierung
- Gutachten einer akkreditierten Materialprüfanstalt

Fire Resistant Barrel Box

Fire resistant drum cabinet for storage of flammable liquids in drums of up to 200 litres. Suitable as a tapping point for hazardous materials at the workplace. Benefits: chemically highly stable internal and external surfaces, with ground clearance for easy lifting and low price. The drum cabinet provides 90 minutes fire resistance.

Function

- Complies with the requirements of the Technical Regulations for Hazardous Material 510, Act on the Regulation of Matters Relating to Water, Hazardous Materials Safety Regulations, Ordinance on Installations Handling Materials Hazardous to Water
- Fire resistance 90 minutes: fire resistant
- EI 90/F 90 classification
- Expert opinion by an official material testing institute



- Hydraulischer Türschließer
- Hydraulic door closer

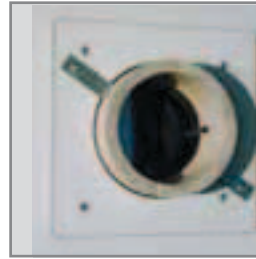

- Lüftungsklappe auf der Decke
- Ventilation flap, top view



- Wannenföden
- Tank bottom



- Metallgriffe
- Metal handles



- Auffangwanne mit Gitterrost
- Drain pan with grate



- Unterfahrbarer Sockel
- Plinth with ground clearance for easy lifting

Aufbau

- Fass-Schrank mit hoher mechanischer und chemischer Beständigkeit
- Einlagiger Wandaufbau aus homogenem Vollmaterial
- Abmessungen optimiert für 200 Literfässer mit aufgesetzter Pumpe
- 220 Liter Auffangwanne mit Gitterrost für Gewässerschutz gemäß Wasserhaushaltsgesetz § 19
- Kippsicherer Wannenföden, verstellbar. Mit mittlerer Lochung zur gezielten Abführung von Leckagen
- Abschließbare Türen
- Türschließer mit Feststellanlage und Thermoelementen zur automatischen Türschließung im Brandfall
- Zwei feuerbeständige Lüftungsschotts K90 DN 100 mm für Zu- und Abluft auf der Decke
- Unterfahrbar

Construction

- Drum cabinet with high mechanical and chemical resistance
- Single layer wall structure of homogeneous solid material
- Dimensions optimized for 200 litre drums with added pump
- 220 litre drain pan with grate for water pollution control according to the Water Resources Law § 19
- Tilt resistant tank bottom, adjustable. With a central hole for systematic removal of leakage
- Lockable doors
- Door closer with hold-open system for automatic closing of doors in the event of a fire
- Two fire-resistant ventilation bulkheads K90 DN 100 mm for inlet and exhaust air on the ceiling
- With ground clearance for easy lifting

Materialgüte

- Standardoberfläche CPL ist chemisch hochbeständig und feuchtigkeitsunempfindlich
- Baustoff mit Oberflächenbeschichtung, klassifiziert A2 – s1, d0: nichtbrennbar
- Standardoberfläche lichtgrau, ähnlich RAL 7035, Kanten und Fasen dunkel abgesetzt

Material characteristic

- Standard surface CP laminate is chemically highly stable and moisture-resistant
- Building material with surface coating, classified A2 – s1, d0: non-combustible
- Surface light grey, similar to RAL 7035, edges and bevels in different colour

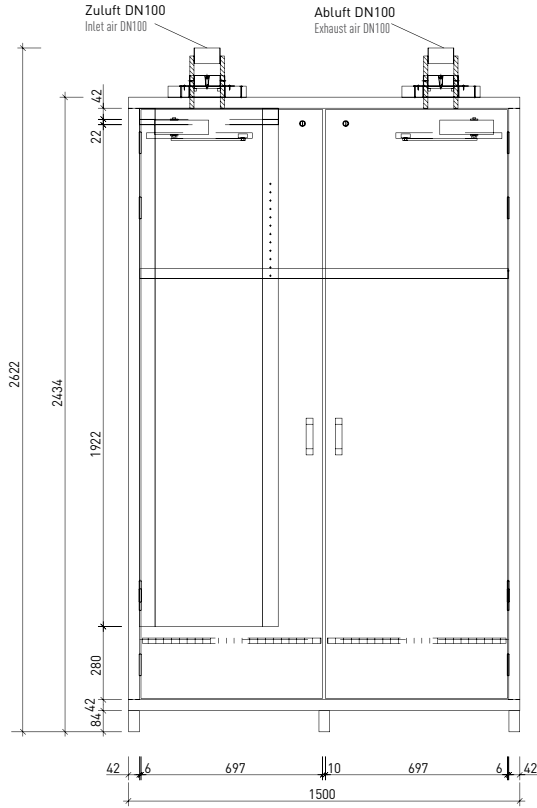

Vorderansicht | Front view

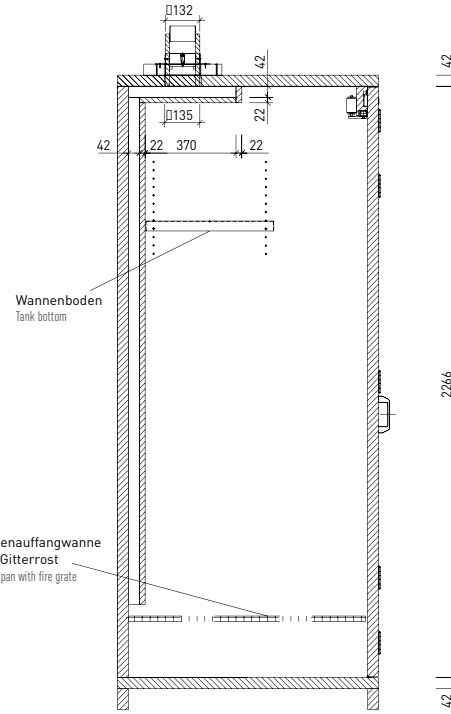



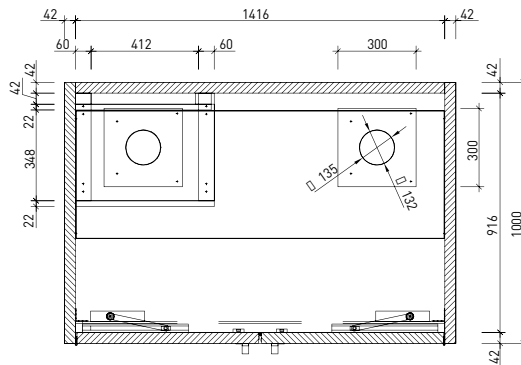

Seitenansicht | Side view

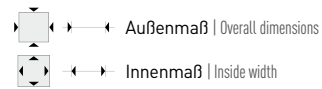

Draufsicht | Top view



Art.	 H x B x T mm	 H x B x T mm	 inkl. Einrichtung incl. equipment kg	Lagervolumen Storage volume	 Liter	Einrichtung Equipment	Beschreibung Description
90 Minuten Feuerwiderstand							
FBX90-Typ2	2622 x 1500 x 1000	1922 x 1416 x 852	1.100	2 x 200 Liter Fässer, aufgesetzte Pumpe möglich	220	Auffangwanne, Wannen- boden	unmontiert auf Palette unmounted on pallets
FBX90				2 x 200 litre drums, mounted pump possible		Drain pan, tank bottom	montiert ab Werk preassembled

Optionen und Zubehör

- Türen oder ganzer Korpus in alternativen RAL-Farben / Oberflächen, auf Anfrage
- Anlieferung auf Palette, Montage vor Ort



EBEL:VENT-EN-U
Umluftaufsatz | Recirculated air attachment
Technische Details siehe Seite: 36
Technical specifications: see page 36



EBEL:VENT-EN-A
Abluftaufsatz | Extract air attachment
Technische Details siehe Seite: 36
Technical specifications: see page 36

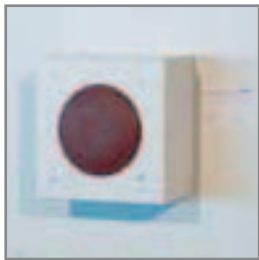

- Feurbeständiges Kabelschott
- Fire resistant cable compartment

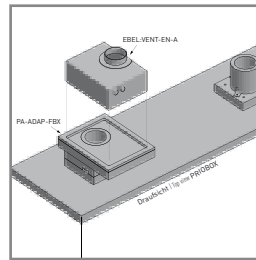

PA-ADAP-FBX
Adapter für den Anschluss von
EBEL:VENT-EN-A
Adapter for connecting EBEL:VENT-EN-A

Art.	Zubehör Accessories
Mechanische Belüftung Mechanical ventilation	
EP.M.8080	Aluminium-Knickfalzrohr - beweglich; D = 100 x 5000 mm; 5 m Stück Aluminium fold-jointed bend pipe - flexible; D = 100 x 5000 mm; 5 m piece
Technische Belüftung Artificial ventilation	
EBEL:VENT-EN-A	Abluftaufsatz, steckerfertig Extract air attachment, ready to plug in
EBEL:VENT-EN-U	Umluftaufsatz, steckerfertig Recirculated air attachment, ready to plug in
HF.SF.9405	Fein-(Vor) filter für EBEL:VENT-EN-U (Ersatz) Fine (pre)filter for EBEL:VENT-EN-U (replacement)
HF.AK.9404	Ersatz-Aktivkohlefilter für EBEL:VENT-EN-U Replacement active charcoal filter for EBEL:VENT-EN-U
PA-ADAP-FBX	Adapter für den Anschluss von EBEL:VENT-EN-A Adapter for connecting EBEL:VENT-EN-A
Einrichtung Equipment	
HF.FBX.6830	Wannenboden Tank bottom
HF.FBX.9831	Schwerlastboden für FBX90; Abmessungen H x B x T: 38 mm x 1413 mm x 850 mm Heavy duty shelf for FBX90; dimensions H x W x D: 38 mm x 1413 mm x 850 mm
Kabel- und Rohrschotts Cable and pipe compartments	
KRS125	Kabel- und Rohrschott d = 135 mm Cable and pipe compartment d = 135 mm
EKRD90-014-014	Einzelkabel- und Rohrdurchführung EN-Schränke Typ90 Single cable and pipe-penetration for EN cabinets, Type 90
Montage Assembly	
FBX90-TYP2-MONT	Montage vor Ort durch PRIORIT Assembly on-site by PRIORIT

Options and accessories

- Doors or entire body in alternative RAL colours / surfaces, on request
- Delivered on pallets, assembly on site